



Project \_\_\_\_\_

Item # \_\_\_\_\_

Quantity \_\_\_\_\_

# Flav-R-Savor® Holding and Display Cabinets

Models: FSD-1, -1X, -2, -2X  
FSDT-1, -1X, -2, -2X

The Hatco Flav-R-Savor® offers a unique concept in food holding and display. Balancing a precise combination of heat and humidity, Flav-R-Savor Cabinets increase sales and profits by reducing waste, maintaining quality and displaying food with appealing design. Utilized in cafeterias, convenience stores, schools, restaurants and supermarkets, Flav-R-Savor Cabinets are a perfect way to merchandise your hot food items such as pizza, fried foods, bakery and more.

Our quick recovery heating system and extremely even temperatures throughout the cabinet eliminate “hot spots” and ensure consistent product quality and long hold times (1 to 4 hours)..

## Standard features

- Energy efficient LED lighting showcases your food product
- Tempered glass door and side panels provide maximum heat retention and allow for full cabinet display
- ¾ gallon (3-liters) stainless water reservoir provides all day moisture, is easily filled through the front mounted water cup and easily drained and cleaned through the inside mounted drain tube
- Low-water protection prevents heating element burnout and alerts operator to low water condition
- 120-volt operation with attached 15-amp cord set operates on a standard outlet, and draws a maximum of 12 amps
- Large access doors are field reversible and will accept a 19" (483 mm) diameter pizza pan

## WATER QUALITY REQUIREMENTS

Water supply in excess of 3.0 grains of hardness per gallon (GPG) (.75 grains of hardness per liter) must be treated and softened before being used. Water containing over 3.0 GPG (.75 GPL) will decrease the efficiency and reduce the operating life of the unit.

**Note: Product failure caused by liming or sediment buildup is not covered under warranty.**

• IFS anti-microbial coatings use naturally-occurring, environmentally sustainable, silver ions to help inhibit the growth of microbes on the powder coated surface. See [www.hatcocorp.com/antimicrobial-paint](http://www.hatcocorp.com/antimicrobial-paint) for more information.

For operation, location and safety information, please refer to the Installation and Operating Manual.



FSDT-1 with standard 4-tier circle rack and optional Designer Black color



FSD-2X with standard 3-tier pan rack, optional mechanical controls and accessory food pans.

## Options (available at time of purchase only)

### Designer Colors\*

Non-standard colors are non-returnable – Clear Anodized Aluminum standard –

- Warm Red  Black  Gray Granite  White Granite
- Navy Blue  Hunter Green  Antique Copper

Mechanical Controls

7½" (191 mm) Display Sign Holder (one per side, three max) (sign not included)

## Accessories

4" (102 mm) Adjustable Legs

Motorless Rack Coupling (for -X models only)

Neutral White (cool) LED lighting (Warm White is standard)

Racks for FSD models only

- 5-shelf Multi-Purpose Rack  3-tier Circle Rack\*  3-tier Pan Rack

Racks for FSDT models only

- 7-shelf Multi-Purpose Rack  4-tier Circle Rack\*  5-tier Circle Rack
- 4-tier Pan Rack  3-shelf Angle Rack  3-tier Pretzel Tree\*

Decorative Kit:

Two Inset Side Panels

(Non-standard colors are non-returnable – Designer Black standard)

- Crescent  Wave

Curved Header

(Non-standard colors are non-returnable – Designer Black standard)

- Hinged for control side  Non-hinged for non-control side

Base Skirts (requires 4" [102 mm] adjustable legs, not included)

(Non-standard colors are non-returnable – Designer Black standard)

- Flat front, back and sides  Curved front, flat back and sides
- Curved front and back, flat sides

\*Requires coupling for -1X or -2X



• IFS anti-microbial coatings use naturally-occurring, environmentally sustainable, silver ions to help inhibit the growth of microbes on the powder coated surface. See [www.hatcocorp.com/antimicrobial-paint](http://www.hatcocorp.com/antimicrobial-paint) for more information.



For operation, location and safety information, please refer to the Installation and Operating Manual.



HATCO CORPORATION | P.O. Box 340500 Milwaukee, WI 53234-0500 U.S.A. | (414) 671-6350



[www.hatcocorp.com](http://www.hatcocorp.com) | [support@hatcocorp.com](mailto:support@hatcocorp.com) | [Find a Hatco Rep](#) | [Image Library](#) | [Document Library](#) | [Patents](#) | [Chat](#)



# Flav-R-Savor® Holding and Display Cabinets

Models: FSD-1, -1X, -2, -2X FSDT-1, -1X, -2, -2X

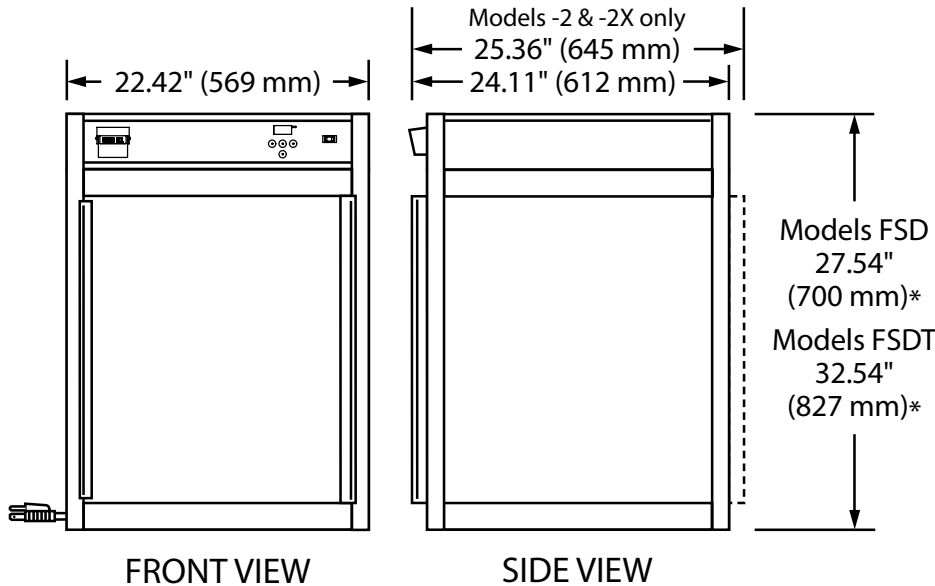

## SPECIFICATIONS

### Holding and Display Cabinets - Standard Height

The shaded areas contain electrical information for International models

Model*	Type	Dimensions (W x D x H†)	Volts	Watts	Amps	Plug	Approx. Ship Weight
FSD-1	1 Door with 3-tier circle rack with motor	22.42" x 24.11" x 27.54" (569 x 612 x 700 mm)	120	1414	11.8	NEMA 5-15P	129 lbs. (59 kg)
			220	1414	6.4	BS-1363, CEE 7/7 Schuko	129 lbs. (59 kg)
			240	1414	5.9	BS-1363, AS 3112	
			220-230 (CE)	1414-1548	6.4-6.7	CEE 7/7 Schuko	
			230-240 (CE)	1297-1414	5.6-5.9	BS-1363	
FSD-1X	1 Door with 3-tier pan rack without motor (not available for retrofit)	22.42" x 24.11" x 27.54" (569 x 612 x 700 mm)	120	1414	11.8	NEMA 5-15P	126 lbs. (57 kg)
			220	1414	6.4	BS-1363, CEE 7/7 Schuko	126 lbs. (57 kg)
			240	1414	5.9	BS-1363, AS 3112	
			220-230 (CE)	1414-1548	6.4-6.7	CEE 7/7 Schuko	
			230-240 (CE)	1297-1414	5.6-5.9	BS-1363	
FSD-2	2 Doors with 3-tier circle rack with motor	22.42" x 25.36" x 27.54" (569 x 645 x 700 mm)	120	1414	11.8	NEMA 5-15P	126 lbs. (57 kg)
			220	1414	6.4	BS-1363, CEE 7/7 Schuko	126 lbs. (57 kg)
			240	1414	5.9	BS-1363, AS 3112	
			220-230 (CE)	1414-1548	6.4-6.7	CEE 7/7 Schuko	
			230-240 (CE)	1297-1414	5.6-5.9	BS-1363	
FSD-2X	2 Doors with 3-tier pan rack without motor (not available for retrofit)	22.42" x 25.36" x 27.54" (569 x 645 x 700 mm)	120	1414	11.8	NEMA 5-15P	126 lbs. (57 kg)
			220	1414	6.4	BS-1363, CEE 7/7 Schuko	126 lbs. (57 kg)
			240	1414	5.9	BS-1363, AS 3112	
			220-230 (CE)	1414-1548	6.4-6.7	CEE 7/7 Schuko	
			230-240 (CE)	1297-1414	5.6-5.9	BS-1363	

\* Non-humidified cabinets available, unit will only operate in dry mode.

† Height includes standard 1" (25 mm) legs.

## CABINET OPENING

FSD models: 19"W x 18.62" H (483 x 473 mm).

## CORD LOCATION

Facing controls, left-hand side panel, lower right corner.

HATCO CORPORATION

P.O. Box 340500 Milwaukee, WI 53234-0500 U.S.A. | (414) 671-6350



[www.hatcocorp.com](http://www.hatcocorp.com)

[support@hatcocorp.com](mailto:support@hatcocorp.com)

[Find a Hatco Rep](#)

[Image Library](#)

[Document Library](#)

[Patents](#)

[Chat](#)



# Flav-R-Savor® Holding and Display Cabinets

Models: FSD-1, -1X, -2, -2X FSDT-1, -1X, -2, -2X

## SPECIFICATIONS Holding and Display Cabinets - Tall

Model*	Type	Dimensions (W x D x H†)	Volts	Watts	Amps	Plug	Approx. Ship Weight
FSDT-1	1 Door with 4-tier circle rack with motor	22.42" x 24.11" x 32.54" (569 x 612 x 827 mm)	120	1414	11.8	NEMA 5-15P	128 lbs. (58 kg)
			220	1414	6.4	BS-1363, CEE 7/7 Schuko	128 lbs. (58 kg)
			240	1414	5.9	BS-1363, AS 3112	
			220-230 (CE)	1414-1548	6.4-6.7	CEE 7/7 Schuko	
			230-240 (CE)	1297-1414	5.6-5.9	BS-1363	
FSDT-1X	1 Door with 4-tier pan rack without motor (not available for retrofit)	22.42" x 24.11" x 32.54" (569 x 612 x 827 mm)	120	1414	11.8	NEMA 5-15P	126 lbs. (57 kg)
			220	1414	6.4	BS-1363, CEE 7/7 Schuko	126 lbs. (57 kg)
			240	1414	5.9	BS-1363, AS 3112	
			220-230 (CE)	1414-1548	6.4-6.7	CEE 7/7 Schuko	
			230-240 (CE)	1297-1414	5.6-5.9	BS-1363	
FSDT-2	2 Doors with 4-tier circle rack with motor	22.42" x 25.36" x 32.54" (569 x 645 x 827 mm)	120	1414	11.8	NEMA 5-15P	126 lbs. (57 kg)
			220	1414	6.4	BS-1363, CEE 7/7 Schuko	126 lbs. (57 kg)
			240	1414	5.9	BS-1363, AS 3112	
			220-230 (CE)	1414-1548	6.4-6.7	CEE 7/7 Schuko	
			230-240 (CE)	1297-1414	5.6-5.9	BS-1363	
FSDT-2X	2 Doors with 4-tier pan rack without motor (not available for retrofit)	22.42" x 25.36" x 32.54" (569 x 645 x 827 mm)	120	1414	11.8	NEMA 5-15P	126 lbs. (57 kg)
			220	1414	6.4	BS-1363, CEE 7/7 Schuko	126 lbs. (57 kg)
			240	1414	5.9	BS-1363, AS 3112	
			220-230 (CE)	1414-1548	6.4-6.7	CEE 7/7 Schuko	
			230-240 (CE)	1297-1414	5.6-5.9	BS-1363	

\* Non-humidified cabinets available, unit will only operate in dry mode.

† Height includes standard 1" (25 mm) legs.

### CABINET OPENING

FSDT models: 19"W x 23.75" H (483 x 603 mm).

### CORD LOCATION

Facing controls, left-hand side panel, lower right corner.

### PLUG CONFIGURATIONS

NEMA 5-15P

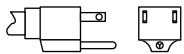

CEE 7/7 Schuko



BS-1363

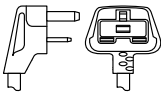

AS 3112

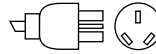

### PRODUCT SPECS

#### Holding and Display Cabinets

The humidity controlled Holding and Display Cabinet shall be a Flav-R-Savor® Model ..., rated at ... volts and ... watts, as manufactured by the Hatco Corporation, Milwaukee, WI 53234 U.S.A.

The cabinet shall have .... door(s), tempered glass sides, stationary rack (or revolving display), and LED display lights. It shall include a water reservoir, humidity selector,

temperature selector, On/Off switch, indicating lights, and a 6' (1829 mm) cord with plug attached.

Accessories shall include adjustable legs, display racks, pans, and merchandising display sign(s).

Warranty consists of 24/7 parts and service assistance (US and Canada only).

**HATCO CORPORATION** | P.O. Box 340500 Milwaukee, WI 53234-0500 U.S.A. | (414) 671-6350



[www.hatcocorp.com](http://www.hatcocorp.com) | [support@hatcocorp.com](mailto:support@hatcocorp.com) | [Find a Hatco Rep](#) | [Image Library](#) | [Document Library](#) | [Patents](#) | [Chat](#)