

PROJECT:	
MODEL # :	
ITEM # :	QTY :
AVAILABLE W/H :	APPROVAL :

Pizza Prep Tables



BAPP44-HC



BAPP67-HC



BAPP93-HC

STANDARD FEATURES

Cabinet construction

- Stainless steel cabinet construction
Stainless steel interior and exterior (galvanized steel back & bottom).
- High density foamed in place polyurethane insulation – Environmentally safe.
- Drop-in section:
Fans force cold air into this enclosed area keeping stored food items consistently cold
- Insulated pan cover with a stainless steel divider which prevents food spillage into the storage area beneath
- Unit accommodates standard 4" or 6" deep pans (pans are not included)
- Epoxy coated wire shelves with adjustable shelving height.
- Side rail cutting board bracket with 19" deep, 1/2" thick cutting board included

- Four (4) 4" diameter swivel casters with front brakes standard.

Refrigeration

- Hydrocarbon refrigerants (R-290) – increases energy efficiency by up to 25% compared to using HFC refrigerants. It is safer for the environment and does not cause ozone depletion.
- Front breathing, side mounted compressor unit. Compressor configuration allows unit to be efficient in narrow spaces and be serviced without being moved.
- Epoxy coated evaporator reduces potential corrosion
- Innovative hot gas frame heating system reduces condensation and increases energy efficiency.
- Refrigerators have a temperature range between 33°F ~ 39°F

Doors

- Self closing doors
- Durable door gasket with easy replacement.
- Lifetime guaranteed heavy duty all metal door handles. (Ni-Cr Plated)

Standard

- NSF/ANSI Standard 7 compliant

Connection

- 9 ft long flexible three wire cord with molded plug

Optional Features & Accessories

- 2.5" diameter casters available
- 6" adjustable feet available
- Additional shelves are available.
- Drawer models available
- 1/3 pans available

Pizza Prep Tables

PRODUCT PLAN VIEW

- Top View -

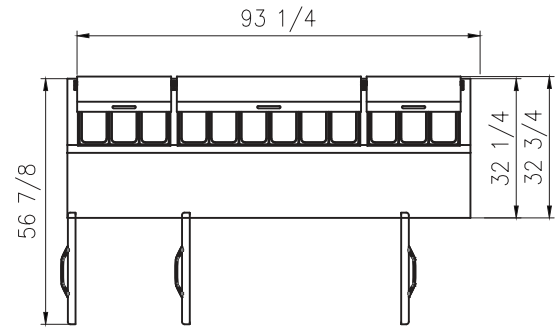
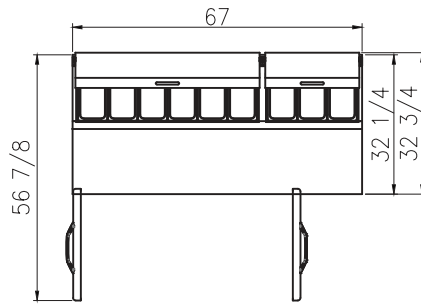
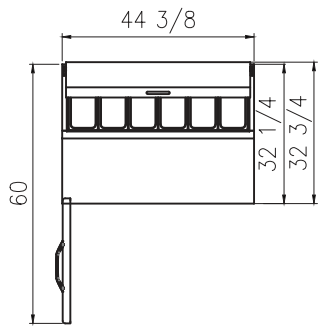

- Front View -

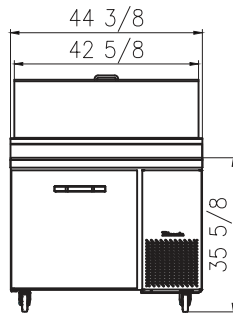

BAPP44-HC

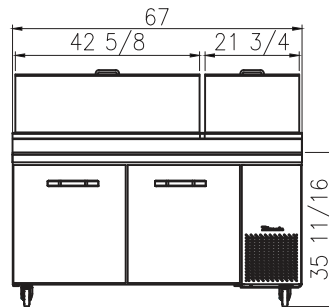

BAPP67-HC

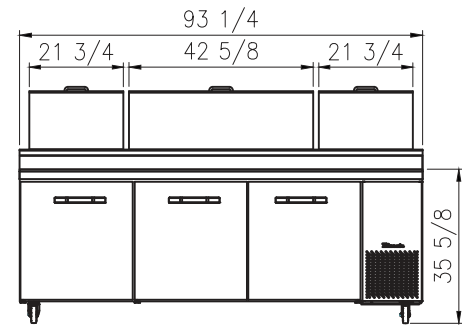

BAPP93-HC

- Side View -

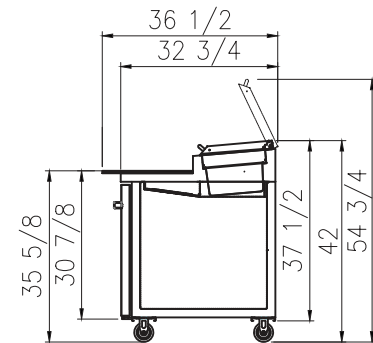

PRODUCT SPECIFICATION

Pizza Prep Tables

Model	Product Description			Refrigerant	Temperature Range	Easy Maintenance			Cord Length (ft/m)			
	Drawers	Capacity (Cu.Ft.)	Shelves	Cabinet Dimensions (inches / mm)			HP	Voltage	Amps	NEMA config.	Weight (lbs / kg)	
				L	D	H					Net Weight	Ship Weight
BAPP44-HC	2	11.3	2	44 3/8 (1127mm)	36 1/2 (927mm)	42 (1067mm)	3/8	115V / 60Hz	3.5	NEMA 5-15	320 (145)	337 (153)
BAPP67-HC	4	20.2	4	67 (1702mm)	36 1/2 (927mm)	42 (1067mm)	3/8	115V / 60Hz	3.5	NEMA 5-15	423 (192)	452 (205)
BAPP93-HC	4	30.8	6	93 1/4 (2369mm)	36 1/2 (927mm)	42 (1067mm)	3/8	115V / 60Hz	3.5	NEMA 5-15	514 (233)	553 (251)

*BLUE AIR has the right to change specifications without further notice.